

EE 435

Experiment 5

Spring 2022

Fully-Differential Two-Stage Op Amp Design

In the previous experiment a two-stage operational amplifier with a single-ended output was designed. In this experiment emphasis will be on a two-stage fully-differential structure that incorporates an output stage to dramatically reduce the output impedance of the amplifier.

I. Discussion

The fully-differential two-stage op amp is widely used. The most basic fully-differential two-stage op amp structure is shown in Fig. 1. A common-mode feedback circuit (CMFB) is necessary to stabilize the operating point of this structure and is also shown as a block in this structure. A popular CMFB is shown in Fig. 2 using p-channel inputs to the differential pairs. This might be most useful when establishing CMFB voltages close to V_{SS} . The corresponding CMFB using n-channel inputs (simply the counterpart circuit) to the differential pairs may be needed if biasing at quiescent voltages closer to V_{DD} .

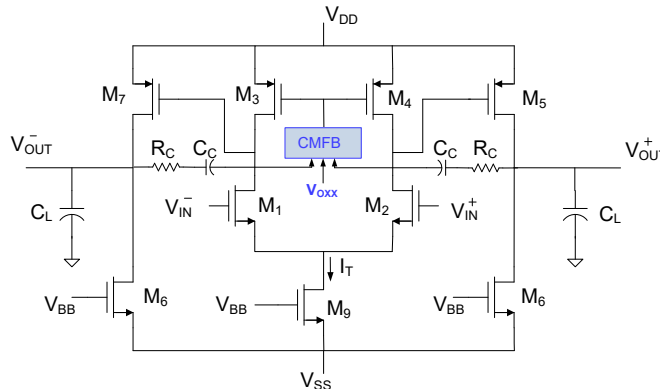

Fig. 1 Basic Two-Stage Fully Differential Operational Amplifier

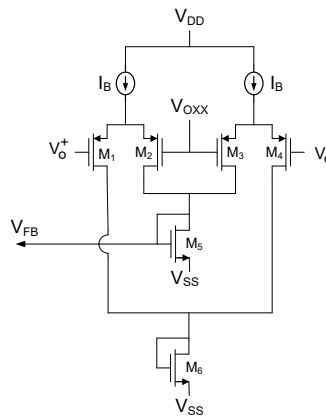

Fig. 2 Continuous-Time CMFB

The output impedance of the fully-differential operational amplifier of Fig. 1 is quite high. When driving resistive loads or a resistive feedback network, the open loop gain of the operational amplifier is adversely affected by the loading effects of the resistive load and the beta network. The corresponding reduction in the open loop gain due to the loading can be dramatic. Fortunately the loading effects can be significantly reduced by including an output stage on the output. The output stage is generally quite simple and often is little more than a common-drain structure though push-pull output stages that offer potential for larger signal swings on the output are often used. In this experiment you will be expected to include an output stage in the amplifier as well.

A fully differential feedback amplifier is shown in Fig. 3. This is a typical application of a fully-differential feedback amplifier. Note that the feedback network is comprised of four 20K resistors. In this experiment, the fully differential amplifier will be designed to support this specific feedback application.

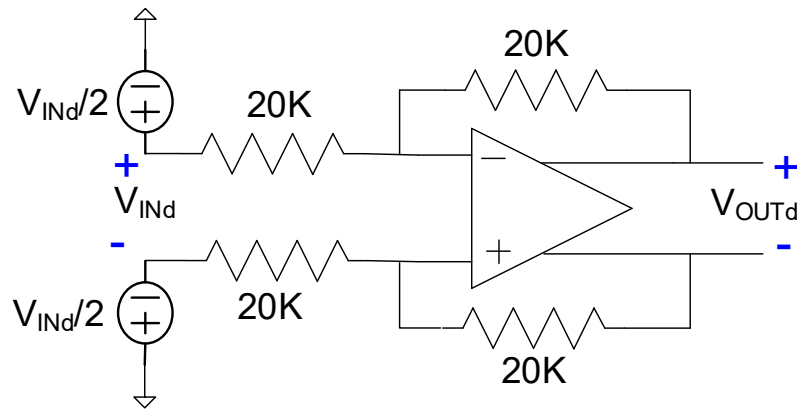

Fig. 3. Fully-differential Feedback Amplifier

II. Laboratory Requirements

1. Obtain the differential voltage gain of the feedback amplifier of Fig. 3. Also obtain the β of the feedback amplifier.
2. Design a two-stage fully-differential operational amplifier in the ON 0.5 μ CMOS process using the basic architecture of Fig. 1, an output stage of your choice, and the CMFB of Fig. 2 for the specific feedback application of Fig. 3. The operational amplifier should meet the following specifications.
 - DC differential open loop gain (including loading of the beta network) in excess of 65 dB.
 - GB in excess of 1.5 MHz.
 - Differential Gain Phase margin between 45 and 60 degrees with the beta network of Fig. 3 when $C_L = 10\text{pF}$ on both outputs.
 - CMFB feedback loop phase margin of at least 45 degrees
 - $V_{DD} = 2.5\text{V}$, $V_{SS} = -2.5\text{V}$
 - Quiescent output voltages of 0V ($V_{OXX} = 0\text{V}$)
 - Output signal swing of at least 2V p-p
 - Random Input Offset voltage of at most 20mV (2σ value).

Give the common-mode input range and the output range of your amplifier and compare with simulated results. The design should include a complete circuit schematic and SPICE simulation results that compare analytical performance with simulated results. A layout of the circuit is not necessary.

Report Requirements

Include a discussion of how you approached the design including the design flow that you established, a discussion of how many degrees of freedom that are available and how you used each one. Also include your spreadsheet that you used to explore the design space and compare the performance requirements you predicted with the spreadsheet with what you actually verified with simulations. Your report should include complete circuit schematics.